

AseptiBag Gold

3D Single Use Systems for Large Volume Storage and Transfer (for Rectangular Totes)

Biopharmaceutical process involves a very wide range of process fluids such as media, growth regulators, harvests, post centrifuge supernatants, buffers, process intermediates, drug substance and formulations.

A critical requirement is storage and transfer of these fluids during and between process step(s) as well as between different process areas. Process owners using conventional reusable storage and transfer systems involving glass bottles, large carboys or stainless steel vessels face multiple challenges in terms of extraneous contamination due to multiple open system handling, cleaning validation and documentation, limited availability of storage space (specially at low temperatures up to - 80 ° C) due to large footprint and issues of safe transportation.

Single Use Systems

Single use disposable pre-sterilized storage and transfer systems help overcome all the above functional challenges and help achieve greater regulatory compliance. These systems however, need to address user concerns with respect to integrity and strength, sterility, endotoxins, biosafety, extractables, particle/fiber release that may impact the identity, strength, quality and purity of the process fluids.

MDI **AseptiBag** Gold 3D systems provide validated and reliable single use disposable solutions for biopharmaceutical process requirements such as storage and transfer of sterile media, process intermediates, sterile buffers with wide ranging pH, sterile drug substances and formulations. These are well characterized for various physical, chemical and microbiological properties to alleviate all the above mentioned concerns.

AseptiFlex-D

Datasheet

The Heart of AseptiBag Gold Systems

The MDI **AseptiFlex-D** Film type FBG-1 is a highly inert, multilayered polyethylene film specially designed for bioprocess applications.

The film is physically tough and inert to chemicals and solvents used in the biopharmaceutical industry and the various layers of the film provide an excellent barrier to Oxygen, CO₂ and moisture.

The contact layer is 130 µm ultra low density Polyethylene layer without any additives.

The AseptiFlex-D film is produced in classified areas through validated processes to ensure consistently high quality meeting various regulatory as well as functional requirements.

Deeply characterized and validated

AseptiFlex-D has been extensively characterized after gamma irradiation at 50 kGy to deliver high performance:

High strength and flexibility: for safety and integrity during handling, storage and transport

Test		Reference Standard	Average Values
Tear strength	TD	ASTMD1938	25.556 N
	MD		17.873 N
Puncture Resistance		EN14477	10.9578 N
Tensile Strength (MD)		ASTMD-882	27.0298 N/mm ²
Flex Durability Test (Gelbo)		ASTM F-392	Passes

Protection of stored liquids from oxidation, change in pH and change in concentration of critical components: with high barrier properties for Oxygen (O₂), Carbon dioxide (CO₂) and water vapour (WV)

Test	Reference Standard	Average Values
O ₂ Transmission Rate	ASTMD3985-05	0.168 cc/m ² /day
CO ₂ Transmission Rate	ASTMF2476	<1.0 cc/m ² /day
WV Transmission Rate	ASTMF1249-13	0.879 g/m ² /day

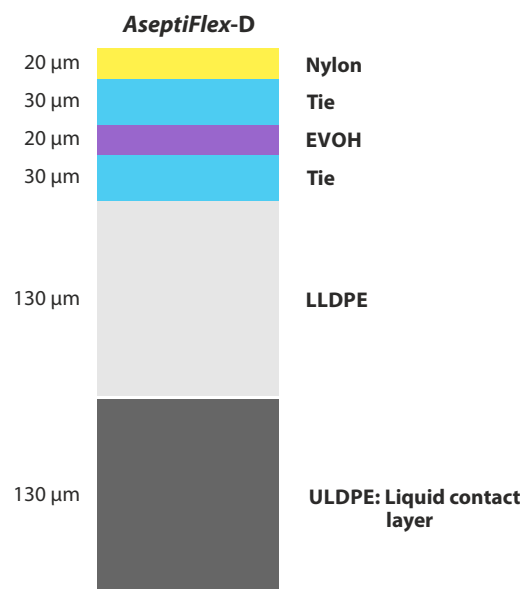

Biocompatibility for media storage and cell growth:

AseptiFlex film is made of plastics of Non Animal Origin and is validated for Biological Reactivity tests as per USP

Test	Reference Standard	Result
Intracutaneous Toxicity	Biological Reactivity Tests, <i>In Vivo</i> , as per USP <88>	Passes
Acute Systemic Toxicity		Passes
Muscle Implantation		Passes
Cytotoxicity	Biological Reactivity Tests, <i>In Vitro</i> , USP <87>	Passes

No impact on purity of process fluids: Very low extractable profile

Test	Reference Standard	Result
Non Volatile Residue	as per USP <661>	Passes
Heavy Metals	as per USP <661>	Passes
Buffering Capacity	as per USP <661>	Passes
Effect on WFI	as per USP <1231>	Passes

AseptiBag Gold 3D

Unique Features and Applications

AseptiBag Gold is made from AseptiFlex-D film offering multiple advantages such as:

- Very low extractable profile for low 'Product' risk
- Long term storage of media and cell growth
- Stability at very low temperatures of up to -80°C
- Higher strength and flexibility

Unique Features

- 100% integrity tested with pressure leak test
- High barrier properties for protection of product molecule, product pool and media components
- Robust and flexible with high burst strength
- Easy inlet and outlet quick connections
- User friendly easy to hold/hang design
- Custom designed to suit user specific process applications

Applications

MDI AseptiBag Gold systems are used for critical biopharmaceutical process steps such as:

- Long term aseptic storage of sterile media, buffers and drug substances at low temperatures
- Transfer of sterile media to bioreactors
- Transfer of process intermediates between process areas
- Aseptic transfer of drug substance to formulation facilities



**Easy Inlet/outlet
Quick Connections**



Validated Pinch Clamps



Leak Proof Ties

AseptiBag Gold 3D

Datasheet

Customized Single Use Systems

MDI works closely with the process owners in biopharmaceutical manufacturing to understand their application requirements in order to establish the technical feasibility of a single use system (SUS) in terms of size, pressure, temperature, complexity of the system as well as compatibility, and to design customized systems by integrating *AseptiBag Gold* with a wide range of pre-qualified components such as membrane capsule filters, connectors, tubing and fittings.

All the system components are deeply characterized and validated for microbial retention, bio-burden, bacterial endotoxins, biosafety and extractables etc to minimize 'product risk' and maximize regulatory compliance.

These customized systems are realized from user approved drawings with detailed definitions of materials of constructions, pore size and dimensions.

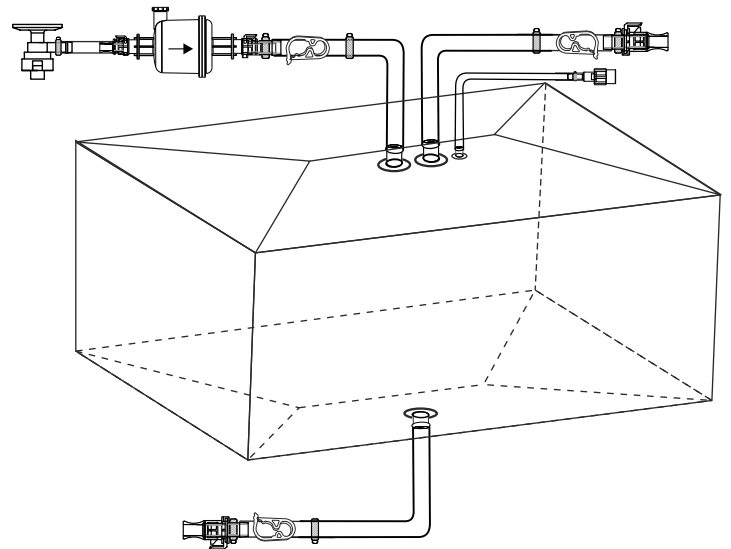

Components

Sterilizing grade membrane capsule filters

MDI capsule filters with PES and hydrophilic PVDF membranes are available in different pore sizes, sizes and end connections for sterile filtration of cell culture media, buffers, drug substance and drug formulations. To know more, visit the link:

<http://www.mdimembrane.com/microfiltration/product-by-type/capsule-filter>

Tubing

MDI offers multiple tubing options of thermoplastic elastomers (TPE) as well as platinum cured silicone. These are available in a wide range of internal and outer diameters to meet the process requirements with respect to fitment into peristaltic pump and to different size hose connections.

TPE tubing offers chemical compatibility with a wide range of organic solvents and buffers. These are heat weldable to allow leak free sterile connections for sampling and storage applications.

Platinum cured silicone tubing offers enhanced flexibility for easy integration into single use systems and for use in peristaltic pumps.

Fittings

A wide range of MDI gamma stable fittings such as cross connections, T connections, Y connections and reducers are available to support various plumbing requirements within these customized single use systems.

Quality Assurance

MDI quality management system emphasizes on quality by design rather than by end product testing only. Robust processes are developed for product manufacturing and are continuously monitored to ensure that the products meet their predetermined specifications and lot to lot reproducibility is ensured.

MDI *AseptiBag* Gold single use storage and transfer systems are produced by trained personnel in validated ISO class 7 facilities under ISO 9001 quality management systems using validated production processes.

Each lot has well compiled batch manufacturing records that ensure complete traceability of raw materials, machines, in process controls, personnel and quality control test data.

These are tested and validated as per international standards and guidelines such as CFR, ASTM, ISO and USP and supported by well designed, state of art physical, chemical and microbiology laboratories.

100% Integrity Tested

Each *AseptiBag* Gold is tested for integrity to comply with validated Acceptable Integrity Test Specifications.

Pressure, Temperature Endurance

AseptiBag Gold systems are validated to endure operating pressure and wide temperature conditions which may be encountered during use.

These bags are also validated for burst pressure with liquid to ensure user as well as product safety in case of inadvertent pressure build-up.

Bioburden Testing

Device bioburden is tested as per ISO 11737-1 and assured to be <1000 cfu/bag.

Biosafety

Passes Biological Reactivity test, In-Vivo, as per USP <88> for Class VI plastics

Passes the Biological Reactivity Tests, In Vitro for Cytotoxicity as described in USP <87>

Endotoxin Testing

Aqueous extracts exhibit < 0.125 EU/ml as established by Limulus Amebocyte Lysate (LAL) Test as per USP <85>

Extractables

Extractables/leachables from sterile containers, used at various stages of a biopharmaceutical manufacturing process, will add on and may impact the impurity profile of the desired product.

AseptiBag Gold systems are validated to exhibit very low extractables under harsh extraction conditions.

Package Integrity

AseptiBag Gold systems are double packed in polybags to ensure package integrity during transit as well as to prevent contamination while transferring to clean room assembly or process areas.

Certificate of Quality

Each lot is accompanied with a Certificate of Quality and the lot number is mentioned on the packaging of each *AseptiBag* Gold storage and transfer system to ensure traceability at the user's end.

AseptiBag Gold 3D

Datasheet

Specifications

Materials of Construction

Bag Film	AseptiFlex-D film type FBG-1
Connection ports	Polycarbonate
Clamps	Polyester
Tubing	Thermoplastic Elastomer
	Platinum cured silicone

Storage Temperature

-80°C to 45°C

Sterilization

Gamma Sterilizable upto 50 kGy

Sterility

The gamma sterilization process has been validated as per ISO 11137 to ensure a sterility assurance level(SAL) of 10^{-6}

Bacterial Endotoxin

Aqueous extracts exhibit < 0.125 EU/ml as established by Limulus Amebocyte Lysate (LAL) Test as per USP <85>

Biosafety

Passes the Biological Reactivity Tests, *In Vivo* for Class VI plastics as described in USP <88>.

Passes the Biological Reactivity Tests, *In Vitro* for Cytotoxicity as described in USP <87>.

Fiber Release

Passes test as per USP and comply with USFDA 21 CFR Part 210.3(b)(6) for fiber release

Particle Release

Complies with USP <788> test for particulate matter in injections

Extractables with WFI

Does not affect the quality of Water for Injection (passes tests as per USP <661>)

Available Sizes

50L, 100L, 200 L, 500 L and 1000L

Dimensions

Bag Size	A	B	C
100 Litre	710 cm	520 cm	310 cm
200 Litre	710 cm	520 cm	610 cm
500 Litre	1100 cm	720 cm	730 cm
1000 Litre	1100 cm	890 cm	1180 cm

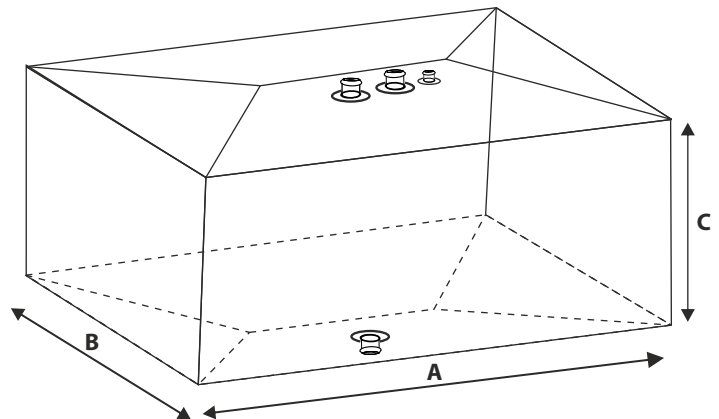

AseptiBag Gold 3D

Datasheet

Chemical Compatibility

Different samples of MDI AseptiBag Gold were filled with specific chemicals/reagents for a specified time period @ 40°C. Post exposure the bags were visually inspected and tested for any leakages, film weight and thickness.

Acceptance Criteria

- ◆ Visual: Color changes, stress marks and clarity
- ◆ Change in weight: $\pm 7\%$
- ◆ Change in thickness: $\pm 10\%$
- ◆ Leakage: No Leakage

Chemical/ Reagents	Exposure	Compatibility
95% Ethanol	7 Days	■
0.5% Chloroform (in IPA)	1 Month	■
100% Ethyl Acetate	7 Days	■
100% Glycerol	7 Days	■
30% Isopropanol	7 Days	■
50% Acetic acid	7 Days	■
1% Citric Acid	7 Days	■
10% HCl	7 Days	■
40% Nitric Acid	7 Days	■
25% Phosphoric Acid	1 Month	■
100% Ethylene Dichloride	7 Days	●

Chemical/ Reagents	Exposure	Compatibility
30% Sulfuric Acid	7 Days	■
Buffer pH 4	7 Days	■
Buffer pH 10	7 Days	■
1M Ammonium Chloride	7 Days	■
2M Sodium Acetate	1 Month	■
0.3M Sodium Acetate	1 Month	■
4M Sodium Chloride	7 Days	■
30% Hydrogen Peroxide	7 Days	■
4-6% Sodium Hypochlorite	7 Days	■
100% Methanol	7 Days	■
100% Chloroform	7 Days	●

- Resistant
- Not Resistant
- Limited Resistance

Customization

MDI works closely with the process owners to understand their application requirements. This storage bag can be customized to suit user requirements regarding tubing sizes, sizes, type of inlet ports, sampling ports, and position and type of drain ports. A technical feasibility of the required design is established based on available components and an initial drawing is proposed. Products prototyping and final approval leads to customized bag realization.

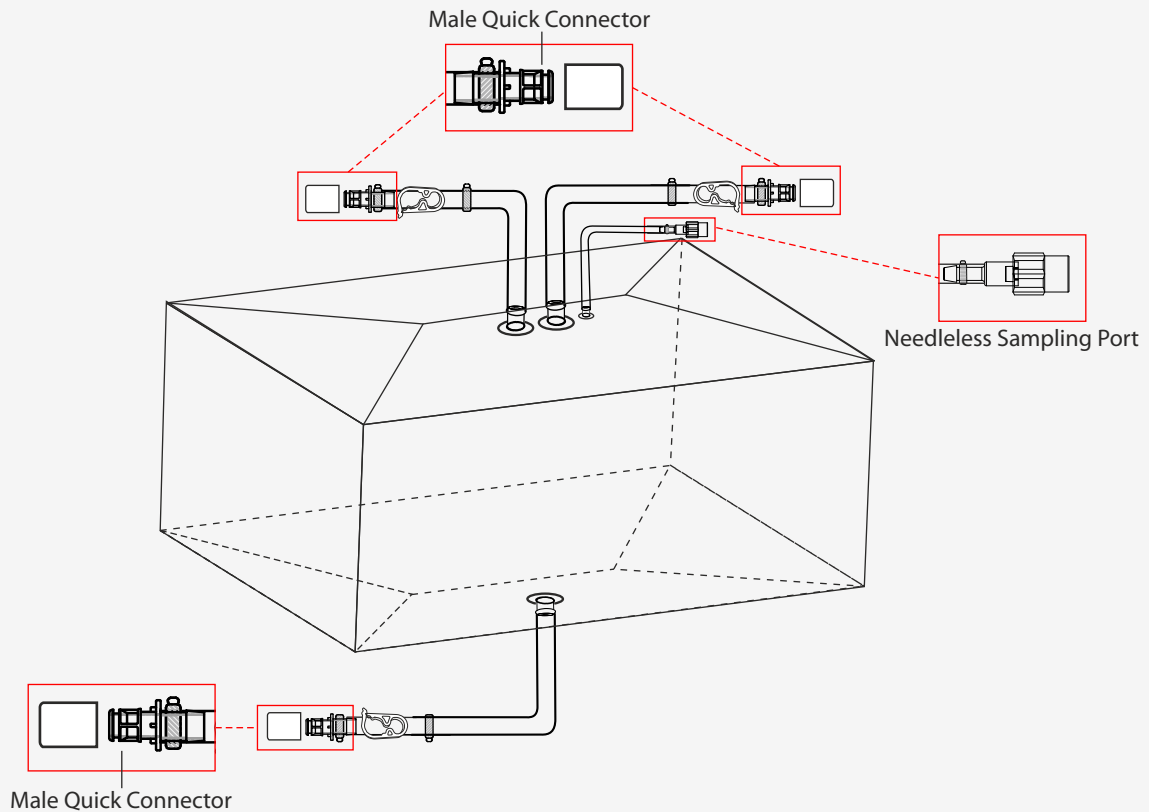

Exclusive distributor for
Germany, Austria and Switzerland.

TECNO PLAST
Member of  **UltraPure**
InternationalGroup

www.tecnoplast.de